

## FITTING INSTRUCTION

Clamp mark in acc. with		Cables joining
ISO	PN	
1	L	Left directional lights
2	+	Rear fog lights
3	31	Ground
4	R	Right directional lights
5	58R	Right side parking lights
6	54	Stoplights
7	58L	Left side parking lights

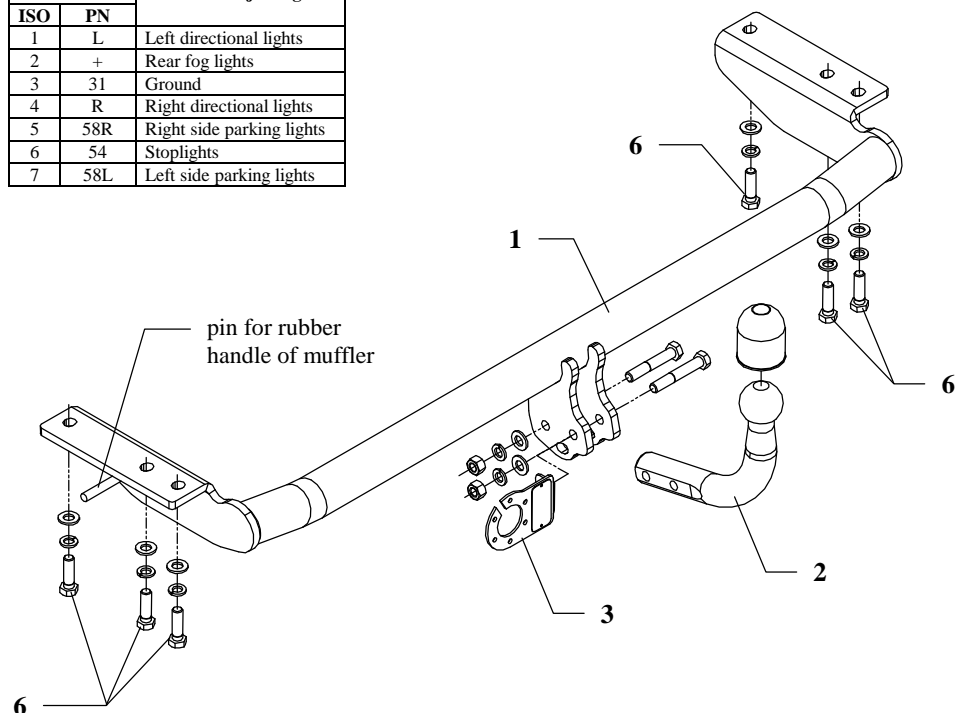

This towing hitch is designed to assembly in following cars: **VOLVO S60** produced since 2000, catalogue no. **L19** and is prepared to tow trailers max total weight **1600 kg** and max vertical load **85 kg**.

### *From manufacturer*

Thank you for buying our product. Their reliability has been confirmed in many tests. Reliability of towing hitch depends also on correct assembly and right operation. For this reasons we kindly ask to read carefully this instruction and apply to hints.

*The towing hitch should be install in points described by a car producer.*

## The instruction of the assembly

1. Clear a trunk and floor. Disassemble a side panels and battery's cover.
2. Disassemble a bumper:
  - if present, disconnect connector on the right side of bumper's floor
  - on rear wall of wall of a trunk remove four bolts fastening a bumper
  - using bit  $\phi 6\text{mm}$  drill two rivets on the underside of wheel casing rims
  - disassemble a bumper
3. In the centre of underside of bumper saw fragment width 50mm and depth 70mm.
4. Underneath on the left side disassemble muffler's handle by loosening two bolts and drilling rivet by bit  $\phi 6\text{mm}$ . Muffler's handle will be not used any more.
5. On the right side disassemble a towing eye. It will be not used any more.
6. In heat shield drill holes  $\phi 5,5\text{mm}$  through existing hole in chassis and rivet it using a rivet from accessories.
7. Apply towing hitch to chassis and fix by bolts M12x40mm (pos. 6).
8. On the left side rubber handle apply on pin of construction of the towing hitch.
9. Fix tow-ball (pos. 2) with socket plate (pos. 3) using bolts M12x75mm (pos. 4) and M12x70mm (pos. 5) from accessories.
10. Tighten all bolts according to the torque shown in the table.
11. Reassemble a bumper - use original bolts and rivets from accessories.
12. Connect electric wires of 7-poles socket according to the instruction of the car. (Recommend to make at authorized service station).
13. Complete paint layer damaged during installation.

Torque settings for nuts and bolts (8,8):	
<b>M 8 - 25 Nm</b>	<b>M 10 - 55 Nm</b>
<b>M 12 - 85 Nm</b>	<b>M 14 - 135 Nm</b>

### NOTE

After install the towing hitch you should get adequate note in registration book (at authorised service station).The car should be equipped with:

- Indicators
- Tow mirrors

After 1000km check all bolts and nuts. The ball of towing hitch must be always kept clear and conserve with a grease.

## Towing hitch accessories:

Pos. 1 Main bar PCS.: 1	Pos. 4 Bolt 8,8 B M12x75mm PCS.: 1	Pos. 8 Plain washer Ø12mm PCS.: 8
Pos. 2 Tow ball PCS.: 1	Pos. 5 Bolt 8,8 B M12x70mm PCS.: 1	Pos. 9 Spring washer Ø12mm PCS.: 8
Pos. 3 Socket plate PCS.: 1	Pos. 6 Bolt 8,8 B M12x40mm PCS.: 6	Pos. 10 Rivet 5x20 PCS.: 3
	Pos. 7 Nut 8 B M12 PCS.: 2	Pos. 11 Ball cover PCS.: 1



## PPUH AUTO-HAK S.J.

Produkcja Haków Holowniczych  
Henryk & Zbigniew Nejman  
76-200 SŁUPSK ul. Słoneczna 16K  
tel/fax (059) 8-414-414; 8-414-413  
E-mail: [office@autohak.com.pl](mailto:office@autohak.com.pl)  
[www.autohak.com.pl](http://www.autohak.com.pl)

## Towing hitch (without electrical set)

Class: **A50-X** Cat. no. **L19**  
Designed for:  
Manufacturer: **VOLVO**  
Model: **S60**  
produced since 2000

Technical data:  
**D-value: 9,1 kN**  
maximum trailer weight: **1600 kg**  
maximum vertical cup load: **85 kg**

Approval number according to Directive 94/20/EC: **e20\*94/20\*0203\*00**

### Foreword

This towing hitch is designed according to rules of safety traffic regulations. The towing hitch is a safety component and can be install only by qualified personnel. Any alteration or conversion of the towing hitch is prohibited and would lead to cancellation of design certification. Remove insulating compound and underseal from vehicle (if present) in the area of the matting surfaces of the towing hitch. The vehicle manufacturer's specifications regarding trailer load and max. vertical cup load are decisive for driving whereat values for the towing hitch cannot be exceeded.

*D-value formula:*

$$\frac{\text{Max trailer weight [kg]} \times \text{Max vehicle weight [kg]}}{\text{Max trailer weight [kg]} + \text{Max vehicle weight [kg]}} \times \frac{9,81}{1000} = D \text{ [kN]}$$